

BA-350/350S* 3/8"-3"

**Bronze Ball Valve
Three Piece
Full Port
600 WOG
Solder Ends
Blow-Out Proof Stem
MSS SP-110**

MATERIALS LIST

ITEM	PART	MODEL/SIZE	MATERIALS	ASTM SPEC.
1	Body	350 & 350S	Cast Bronze	B584
2	Tailpiece	350 & 350S	Bronze	B584
3	Ball	350	Chrome Plated Brass	B16
		350S	316 Stainless Steel (1)	A276
4	Stem	350	Brass	B16
		350S	316 Stainless Steel (1)	A276
5	O-Ring	350 & 350S	Viton	MIL-R-83248
6	Seat	350 & 350S	15% Glass RPTFE	
7	Thrust, Washer	350 & 350S	25% Glass RPTFE	
8	Packing, Male	2-1/2"-3"	PTFE (2 1/2" - 3")	
	Packing, Female	3/8"-2"	PTFE (3/8" - 2")	
9	Packing, "V"	350 & 350S	PTFE	
10	Packing, Female	350 & 350S	PTFE	
11	Packing Follower	350 & 350S	Brass	B16
12	Hex Jam Nut	350 & 350S	Stainless Steel	Commercial
13	Nut Locker	350 & 350S	S.S. Type 301/302	
14	Washer, Internal Tooth	350 & 350S	Stainless Steel	Commercial
15	Belleville, Washer	350 & 350S	S.S. 17-7 PH	Commercial
16	Hex Head Cap Screw	350 & 350S	SAE, Grade 8	Commercial
17	Socket Head Cap Screw	2-1/2"-3"	Commercial Carbon Steel	Zinc Plated
18	Handle Assy	350 & 350S	-	-
19	Gland Nut	3/8"-2"	Brass	B16
20	Hex Nut	3/8"-2"	Commercial	SAE 5140

(1) Ball and stem are stainless for BA350S

PRESSURE and TEMPERATURE CHART

VALVES RATED FOR VACUUM SERVICE TO 29 INCHES Hg.
 ——— Seat Material Rating
 - - - - Solder Joints per ANSI B16.18

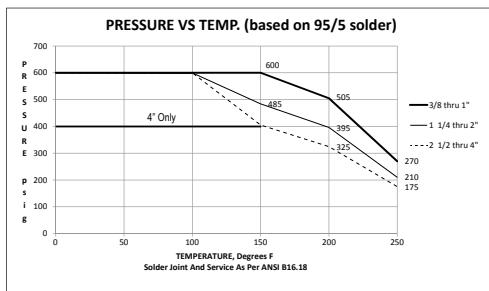

*Not intended for use in potable water.

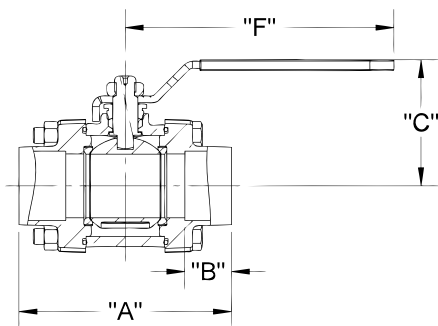
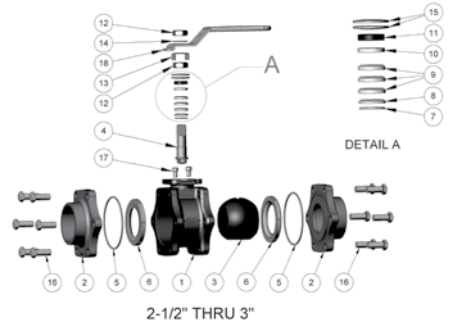
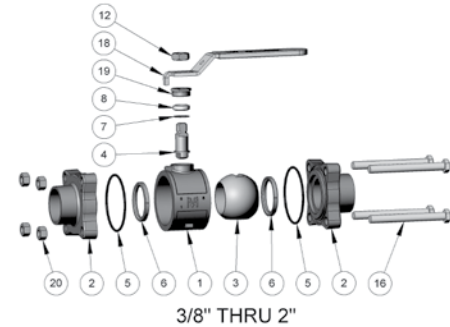

DIMENSIONS

	UNITS	3/8" DN10	1/2" DN15	3/4" DN20	1" DN25	1-1/4" DN32	1-1/2" DN40	2" DN50	2-1/2" DN65	3" DN80
A	INCHES	2.68	3.02	3.56	3.81	4.66	5.00	5.70	7.01	7.01
	mm	68	77	90	97	118	127	145	178	178
B	INCHES	0.44	0.51	0.76	0.92	0.98	1.10	1.35	1.48	1.67
	mm	11	13	19	23	25	28	34	38	42
C	INCHES	1.85	1.85	2.20	2.65	2.79	2.97	3.47	5.44	5.44
	mm	47	47	56	67	71	75	88	138	138
D	INCHES	0.45	0.50	0.75	1.00	1.25	1.50	2.00	2.50	2.50
	mm	11	13	19	25	32	38	51	64	64
E	INCHES	1.32	1.32	2.13	2.41	2.94	3.13	3.86	5.74	5.74
	mm	34	34	54	61	75	80	98	146	146
F	INCHES	3.80	3.80	4.55	6.32	6.32	6.32	7.20	8.10	8.10
	mm	96	96	116	160	160	160	183	206	206
G	INCHES	1.92	1.92	2.13	2.41	2.94	3.13	3.86	6.31	6.31
	mm	49	49	54	61	75	80	98	160	160
Cv		7	17	31	60	110	185	360	390	390

*3" is standard Port.

**2-1/2" & 3" Only.

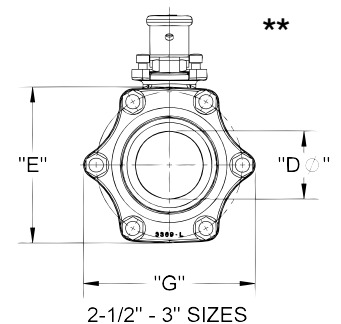

The information presented on this sheet is correct at time of publication. Milwaukee Valve reserves the right to change design and/or materials without notice. For our Installation, Operation and Maintenance Manual and the most current product information go to www.milwaukeevalve.com.
 ⚠ State of California Prop 65 **WARNING: Cancer and Reproductive Harm.** For more information visit www.p65warnings.ca.gov.

