

# BA260LDC 1/4"-3"

**Stainless Steel Ball Valve**  
**Full Port**  
**1000 WOG**  
**120VAC Electric Actuator**  
**Blow-Out Proof Stem**  
**Specifications: MSS SP110**

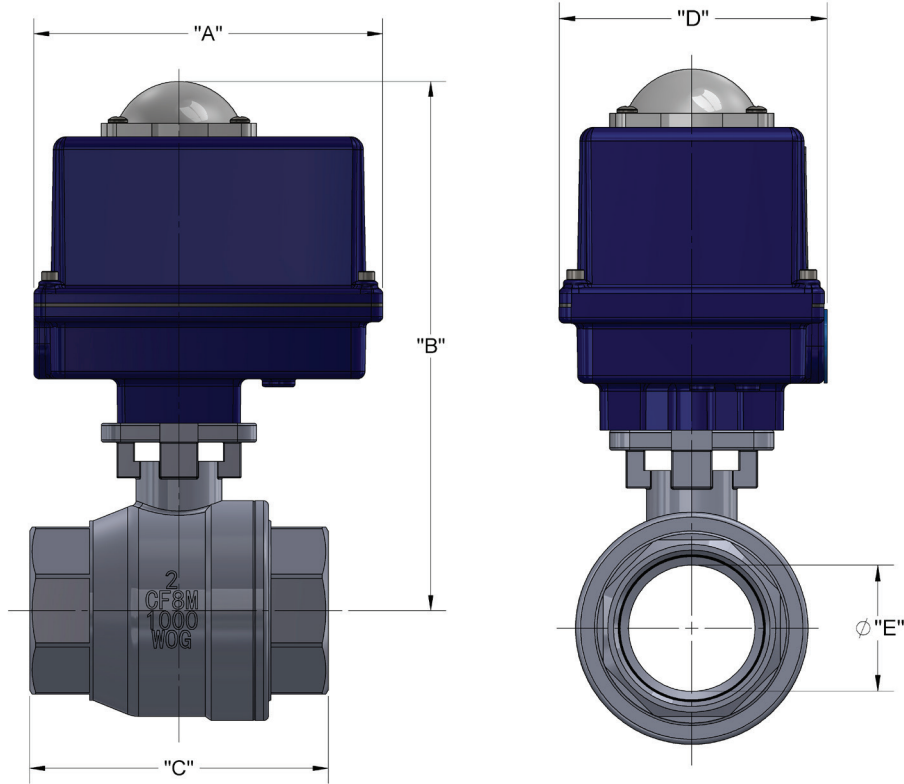

- CF8M (316 SS) two-piece full port
- 316 SS ball and stem
- TFM 1600 PTFE seats and packing
- 1000 psi rated @ 100° F
- Temp range: -20° to 450° F 50 psi SWP
- 120VAC NEMA 4 rated electric actuator
- 25% duty cycle
- Two limit switches / Remote light indication
- Manual override
- Visual position indicator
- For on/off service

AIR TO AIR ACTUATOR ASSEMBLY DIMENSIONS						
Valve	Model	Dimensions in Inches				
Size	Actuator	A "	B "	C "	D "	E "
1/4	MCR100	6.44	7.31	2.64	4.13	0.42
3/8	MCR100	6.44	7.31	2.64	4.13	0.50
1/2	MCR100	6.44	7.31	2.64	4.13	0.59
3/4	MCR100	6.44	7.59	2.76	4.13	0.79
1	MCR200	6.88	8.58	3.35	4.25	0.98
1 1/4	MCR200	6.88	8.78	3.70	4.25	1.26
1 1/2	MCR300	6.88	9.10	4.13	4.25	1.50
2	MCR675	7.00	12.10	4.92	7.00	1.97
2 1/2	MCR675	7.00	13.03	6.10	7.00	2.50
3	MCR1000	7.00	13.32	6.81	7.00	2.99

The information presented on this sheet is correct at time of publication. Milwaukee Valve reserves the right to change design and/or materials without notice. For our Installation, Operation and Maintenance Manual and the most current product information go to [www.milwaukeevalve.com](http://www.milwaukeevalve.com).

⚠ State of California Prop 65 **WARNING:** Cancer and Reproductive Harm. For more information visit [www.p65warnings.ca.gov](http://www.p65warnings.ca.gov).

