

BRONZE GATE VALVES

300 Lb. WOG • Flanged Ends

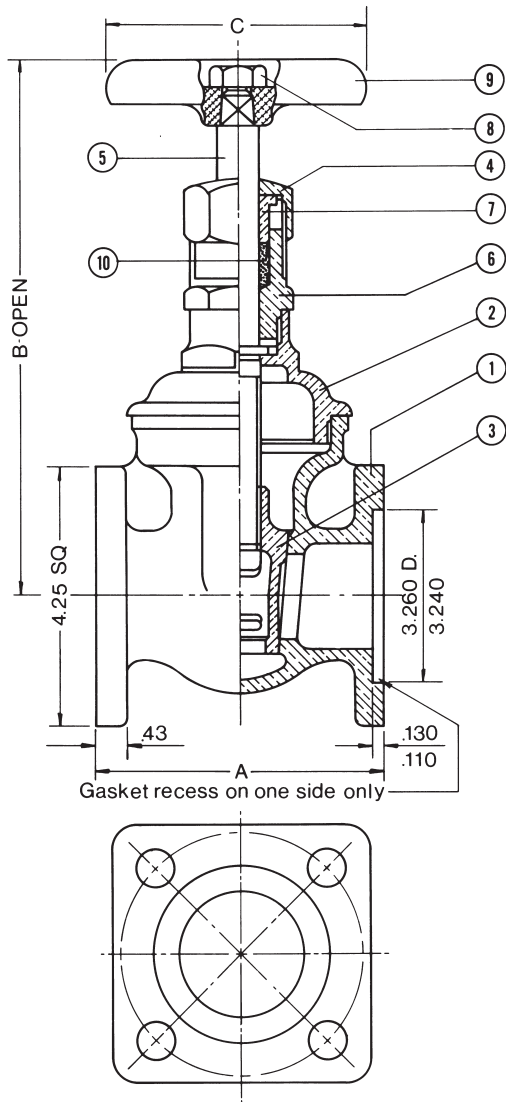

Square flanged ends have 4 holes - $\frac{1}{16}$ " diameter equally spaced on a 4" diameter bolt circle.

P-2641

This flange gate valve is a heavy-duty design, solid wedge, screwed bonnet, non-rising stem with gland packing. Specifically designed for rapid fill or drain and vacuum test.

P-2641 B

Same as P-2641 with bronze hand wheel.

P-2641 B-2

Same as P-2641 B without recess in flange.

P-2641 B-3

Same as P-2641 B with sampling device.

MATERIAL LIST

NO.	DESCRIPTION	MATERIAL & SPECIFICATION
1	Body	Bronze
2	Bonnet	Bronze
3	Wedge	Bronze
4	Stuff Nut	Bronze
5	Stem	Bronze
6	Check Nut	Brass
7	Gland	Brass
8	Wheel Nut	Brass
9	Handwheel	Aluminum
10	Packing	Graphite

DIMENSIONS - INCHES

SIZE	A	B	C
2	3 7/8	7 11/16	3 3/4

Rev.1

